



www.rbdinstruments.com

10-155 Filament Change Procedure

Use gloves, de-magnetize all tools, and clean all tools with isopropyl alcohol.

1. Set the analyzer on a stand or use manuals and support analyzer on the handles, facing up.
2. Remove the outer magnetic shield (4 screws).
3. Remove the inner magnetic shield (4 screws).
4. Carefully remove the conical ceramic.
5. Loosen the VM (outer cylinder) wire and lift the inner cylinder from the base ceramic.
6. Remove the three screws inside the inner cylinder.
7. Carefully lift the inner cylinder up and off of the electron gun assembly.
Note: If the inner cylinder does not move freely, use a heat gun to expand the inner cylinder so that it will slide off. Do not force it!
8. Look at the 10-155 electron gun detail on page 3 to familiarize yourself with the electron gun assembly.
9. Remove the three long screws that hold the electron gun assembly together.
10. Remove the V1 emission screw
11. Remove the two filament couplers from the filament posts. You will need a .048 4 spline wrench.
12. Remove the three filament ceramics.
13. Remove the filament assembly. Note the orientation of the emission tab and filament posts.
14. Remove the three screws that hold the filament base on and remove the filament.
15. Install the new filament in the same orientation as the old filament into the emission cap.
16. Install the filament base, the three screws, and tighten the screws slightly.
17. Position the filament so that it is centered in the hole and tighten the three screws. This is best done using a microscope.
18. Install the filament assembly on top of the three filament ceramics and use the three long screws to hold the assembly together. The three long screws need to be tightened so that they all have the same distance with respect to the base.
19. Reconnect the V1 wire.
20. Reconnect the filament couplers.
21. Ohm out the connections to the filament and V1.
22. Degauss the gun assembly.
23. Install the inner cylinder over the electron gun assembly.

24. Reinsert and tighten the three screws inside the inner cylinder.
25. Reinstall the outer cylinder and attach the VM wire.
26. Carefully install the conical ceramic. The resistor part should be 180 degrees out from the bottom flat ceramic. Ohm out VM to ground and make sure it has the correct resistance.
27. Install the inner magnetic shield.
28. Degauss the analyzer.
29. Install the outer magnetic shield.
30. Degauss the analyzer. Installation complete.

10-155 Electron Gun Detail

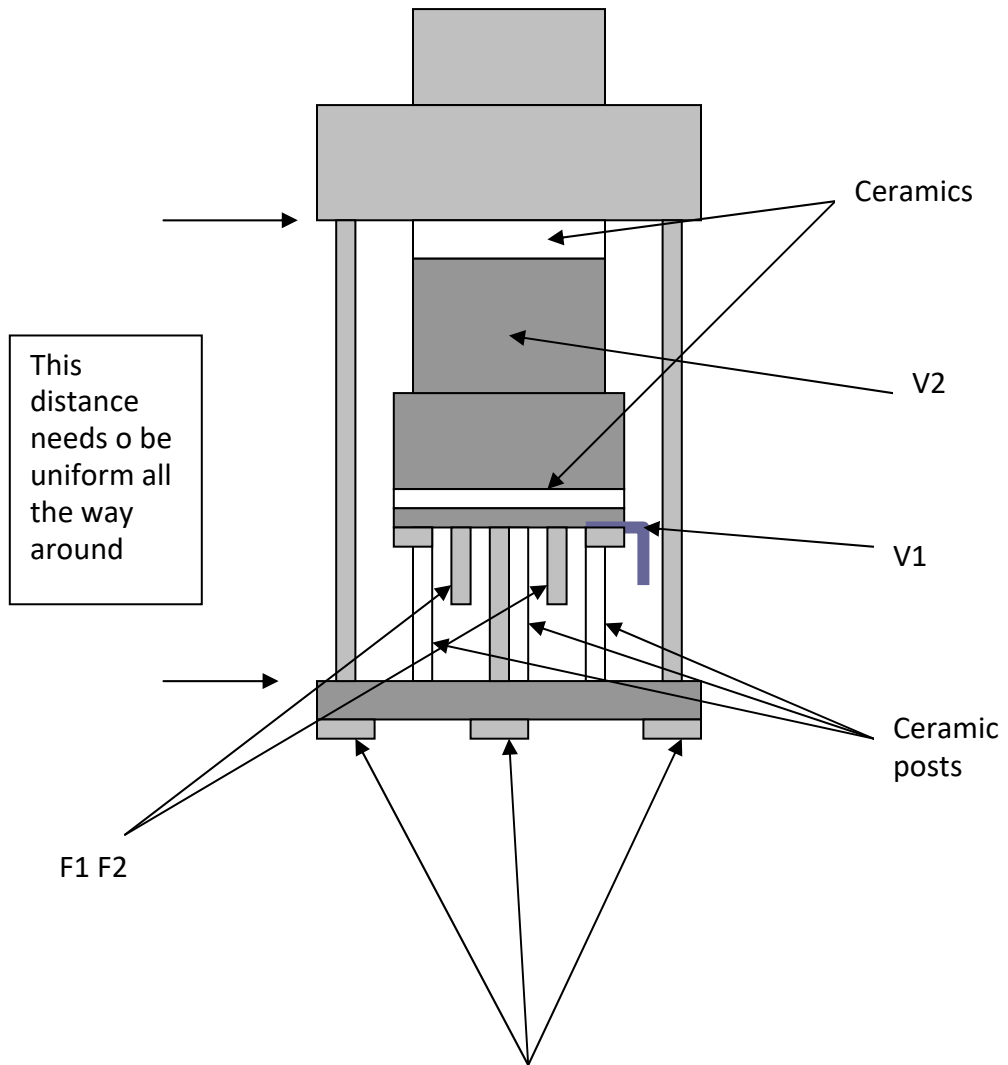

These screws hold the gun assembly together. It is stacked on the ceramics. Tighten it up, but not too much. All 3 screws should have the same distance with-in .001".