

Variable leak valve



INSTRUCTIONS FOR USE	1
SAFETY INFORMATION	1
GENERAL	1
Variable leak valve description	1
Variable leak valve specifications	1
VARIABLE LEAK VALVE OUTLINE	2
FLANGE CONNECTION	2
Inlet gas connection	2
USE	2
To establish a new stop position	3
To set stop position at any leak rate	3
OPERATING AT LOW LEAK RATES	3
CHANGES IN LEAK RATE WITH VARIATION IN ROOM TEMPERATURE	4
BAKEOUT PROCEDURE	4
Bakeout in open position	4
Bakeout in closed position	4
Operation after bakeout	4
TO USE AS A ROUGHING VALVE	4
ADJUSTMENT OF HANDLE POSITION	4
IF VALVE WILL NOT CLOSE LEAK-TIGHT	5
Disassemble	5
Inspect and clean sapphire	5
Inspect and clean valve body	5
Inspect and clean gasket assembly	6
Re-install sapphire assembly	6
Re-install gasket assembly	6
Leak-check and adjust closure	6
LUBRICATION INSTRUCTIONS	6
LOSS OF SENSITIVITY AT HIGH LEAK RATES	7
REPLACEMENT PARTS	8
ACCESSORIES	9

SAFETY INFORMATION

This equipment is destined for use by professionals. The user should read this instruction manual and any other additional information supplied by Varian before operating the equipment. Varian will not be held responsible for any events occurring due to non-compliance, even partial, with these instructions, improper use by untrained persons, non-authorized interference with the equipment or any action contrary to that provided for by specific national standards.

This manual uses the following standard protocol:



WARNING!

The warning messages are for attracting the attention of the operator to a particular procedure or practice which, if not followed correctly, could lead to serious injury.



CAUTION

The caution messages are displayed before procedures which, if not followed, could cause damage to the equipment.

NOTE

The notes contain important information taken from the text.

GENERAL

The variable leak valve can be added to any vacuum system to establish an adjustable leak. It offers unprecedented control sensitivity and stability with leak rates as small as 1×10^{-10} Torr-litres per second. Leak rate adjustment is controlled with knurled knobs. The entire valve, including the drive mechanism, is bakeable to 450°C in either the open or closed position. Both components of the seal mechanism (sapphire assembly and gasket assembly) are easily replaceable.

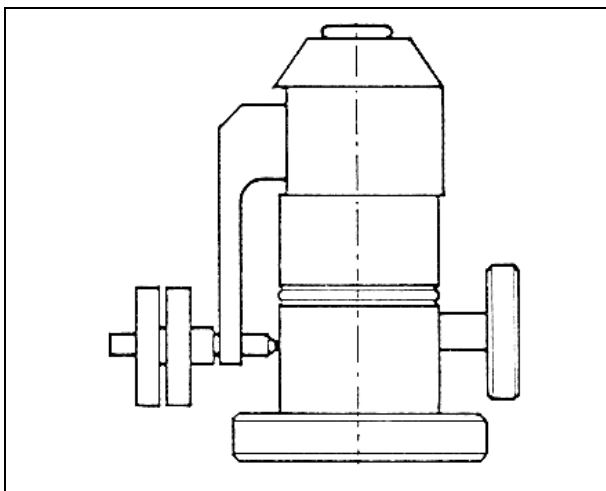

Variable leak valve

Variable leak valve description

The variable leak valve includes a movable piston with an optically-flat sapphire that meets a captured metal gasket (see the following figure). This forms a seal completely free from friction, seizing, and shear. The sapphire's movement is controlled through a threaded shaft-and-lever mechanism having a mechanical advantage of 13,000 to 1. Spring washers keep this drive mechanism constantly loaded and eliminate the backlash usually associated with this type of device. This provides immediate response to small movements in the finger-controlled adjusting knobs. While some permanent compression takes place in the gasket each time a seal is made, the change is very slight. Return of the knob to a previous position will result in approximately the same leak rate.

The valve is shipped in a closed, leak-tight condition.

To open a leak, the knurled knobs must be turned (together) a minimum of two full turns counter-clockwise. The valve is closed by turning the knobs (together) clockwise to the stop position against the handle.

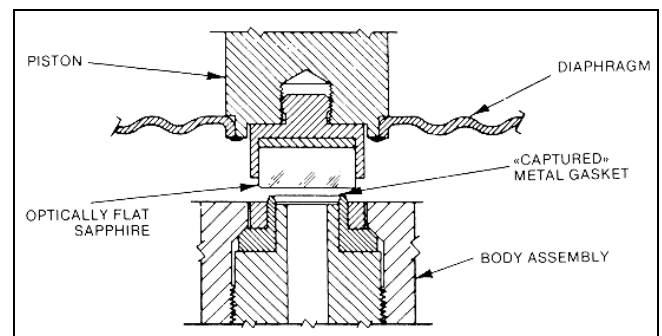

Sealing detail

Variable leak valve specifications

Minimum leak rate	1×10^{-9} Torr-litres/sec. in normal operation; 1×10^{-10} Torr-litres/sec. with condensable vapours eliminated from leak gas
Rate of change of leak	The valve provides an increasing rate of change as the size of the leak increases giving precise control in proportion to the size of the leak
Vacuum range	From atmospheric pressure to below 10^{-11} Torr
Temperature range	Up to 450 C in either open or closed position
Inlet gas pressure	500 psi maximum
Gasket life	For unbaked systems, approximately 300 closures; For baked systems, 20 to 30 closures Gasket assemblies are replaceable
Material	300 series stainless steel; sapphire; OFHC copper and copper alloy
Weight	1.8 Kg (4 lbs)

VARIABLE LEAK VALVE OUTLINE

The outline dimensions for the variable leak valve are shown in the following figure.

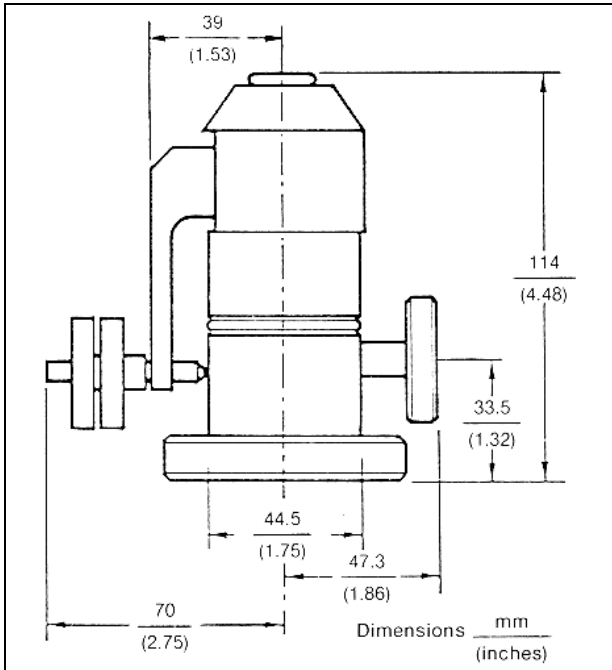

Variable leak outline

FLANGE CONNECTION

The valve is shipped in a closed, leak-tight position, lubricated and ready for installation.

The ConFlat flange on which the variable leak valve is mounted mates with any 2 1/4 inch O.D. ConFlat flange.

1. Place a new copper gasket (Varian part no. 953-5014) between the two ConFlat flanges.
2. Lubricate and install bolts and nuts. Use Fel-Pro C-100 high temperature lubricant on screw threads and under the nuts.
3. Tighten each nut 180° apart in sequence to 5 to 8 ft-lbs torque. This will partially close the gap between the flange faces. Repeat the sequential tightening two more cycles.
4. The copper gaskets are partially sheared in making the seal and the bolts should be tightened until the flange faces meet.
5. Leak-check the connection.

Inlet gas connection

The connection is made through standard Mini-Con- Flat flanges.

A Mini-ConFlat flange-to-flare-fitting adapter kit (Varian part no. 951-5117) is provided as an option.

1. Place a new copper gasket (Varian part no. 953-5014) between the two ConFlat flanges.
2. Lubricate and install bolts and nuts. Use Fel-Pro C-100 high temperature lubricant on screw threads and under the nuts.
3. Tighten each nut 180° apart in sequence to 5 to 8 ft-lbs torque. This will partially close the gap between the flange faces. Repeat the sequential tightening two more cycles.
4. The copper gaskets are partially sheared in making the seal and the bolts should be tightened until the flange faces meet.
5. Leak-check the connection.

USE



WARNING!

The main danger of explosion in vacuum equipment occurs during backfilling from pressurized gas cylinders.

Explosions cause flying debris which may cause serious personal injury or death and destroy equipment.

The following precautions must be exercised when admitting gas into a vacuum system:

1. Check that the leak valve is in the closed position before admitting gas into the backfill line.
2. Always use a pressurized relief valve in the backfill line.



CAUTION

Never operate the valve without knowing the relationship of the stop position to the point of leak tight closure. The point at which the valve closes cannot be felt by the operator and severe overdriving may fracture the sapphire.

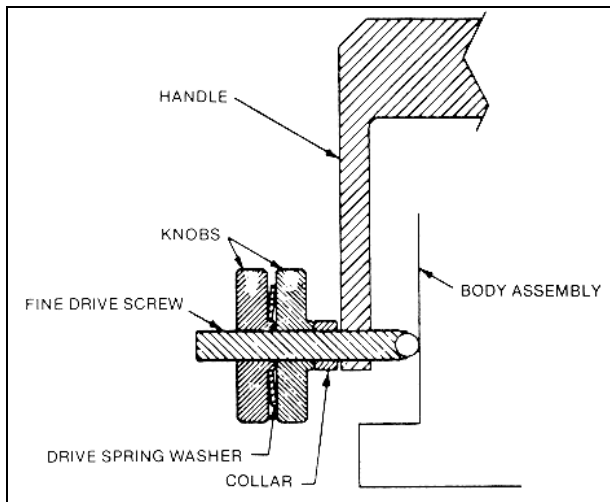

Knob adjustment

The valve is received in a closed, leak-tight position. The adjusting knurled knobs are tightened against the handle.

During normal operation, the knobs are locked together with respect to the fine-drive screw. To open a leak, turn both knobs together a minimum of two full turns counterclockwise. To close a leak, turn the knobs together until the collar butts against the handle (the stop position has been reached).

To establish a new stop position

Each time a seal is made, the valve's captured metal gasket is compressed. High temperature bakeout accelerates the compression of the gasket. If no change is made to the position of the knobs on the fine-drive screw, the point of closure will gradually come closer to the point at which the knobs and collar butt against the handle. Eventually the stop will be engaged before a leak-tight closure is made. When this happens, a new stop position must be established.

1. The valve must be attached to a leak detector or the system must be equipped with gauging adequate to determine when no leak exists.
2. With the knobs tightened against the handle, unlock the knobs from each other by holding the inner knob and turning the outer knob counterclockwise about four turns.
3. Turn the inner knob counterclockwise until it is locked tight against the outer knob.
4. Turn the two locked knobs clockwise until the valve closes as indicated on the leak detector or system gauging.
5. Turn the knobs clockwise two additional turns past the point of closure.

6. Loosen the knobs from each other without allowing the screw to turn. Turn the inner knob clockwise until the collar is against the handle, then turn the outer knob clockwise until it locks against the inner knob. The knobs are now in position to return to and stop at a point two turns past closure.
7. After the stop has been adjusted several times, the handle must be reset as described in para. "Maintenance".

To set stop position at any leak rate

The stop position can be adjusted to provide any desired leak rate.

1. Open the valve to the desired leak rate as determined by a leak detector, vacuum gauge, or other experimental means.
2. Loosen the knobs from each other without allowing the fine-drive screw to turn.
3. Turn the inner knob clockwise until the collar stops against the handle. Turn the outer knob clockwise until it locks against the inner knob.
4. The valve can now be opened to larger leak rates and when returned to the stop position will provide a leak of this pre-set rate.

NOTE

The valve cannot be closed leak-tight with the stop set in this manner. To close the valve, follow the procedure outlined in the preceding paragraph.

OPERATING AT LOW LEAK RATES

When the valve operates with leak rates of 1×10^{-9} Torr-litres/sec and smaller, condensable vapours and contaminants reduce the leak opening. The valve must be baked to 250° in the open position and under vacuum for 30 minutes to drive off these internally adsorbed vapours. See the paragraph "Bakeout procedure".

For operation at leak rates of 3×10^{-10} Torr-litres/sec and lower, in addition to the bakeout described above, the inlet gas must be free of condensable vapours. Use a dry gas or pass the inlet gas through a drying agent such as a liquid nitrogen cold trap. A molecular sieve trap can be used for drying the gas but a filter must be employed to assure that no particles of sieve enter the valve.

CHANGES IN LEAK RATE WITH VARIATION IN ROOM TEMPERATURE

Changes in room temperature will cause changes in leak rate - as the temperature rises, the leak rate increases. A leak setting should be made in the range of interest and then mild heat applied to raise the temperature of the valve to the maximum expected value. If the resulting change in leak rate is not acceptable to the intended experiment, some means of temperature control should be used.

BAKEOUT PROCEDURE

Bakeout in open position

- a) No special steps are required to bake the leak valve in the open position.
- b) A leak that has been set with the valve at room temperature will increase due to thermal expansion as the valve is heated during bakeout. Monitoring of system pressure and re-adjustment of the leak is necessary if a constant leak is desired during temperature cycling.

Bakeout in closed position

- a) The valve must be overdriven three turns past closure (normal setting is two turns) to compensate for differential expansion of materials during bakeout.
- b) To prepare the valve for bakeout, follow the procedure described in paragraph "To establish a new stop position" with the following exceptions: in steps 5 and 6, substitute "three turns" for the "two turns" specified.

Operation after bakeout

- a) Bakeout in the closed position to 250°C and above will increase the size of leak for a given setting of the knobs. A full three turns may not be required to open a leak after bakeout. Length of bakeout and elapsed time at temperature will both affect the amount of change.
- b) If the stops are to be re-adjusted, follow the procedure described in steps "a" and "b" above.



CAUTION

After each bakeout cycle, before opening or closing the valve, tighten the outer knob against the inner one and lubricate the threads of the fine drive screw with Fel-Pro C-100. After every three bakeouts over 300°C, disassemble and lubricate the drive mechanism as described in the following para. "Lubrication instructions".

TO USE AS A ROUGHING VALVE

The variable leak valve can be used as a roughing valve when pumping small vacuum systems (some litres volume). The valve must be opened to its maximum conductance for this operation.

Connect a roughing pump to the inlet gas fitting. Where available, install a molecular sieve or liquid nitrogen trap in the line between the pump and valve to reduce contamination from mechanical pump oil vapours.

ADJUSTMENT OF HANDLE POSITION

As described previously, continual reduction in gasket height necessitates resetting of the stop position and eventual re-adjustment of handle position. When the angle between the handle and body at point of closure has changed from its original parallel (approximate) position to an angle of $\pm 5^\circ$, the valve should be readjusted. This adjustment will maintain a proper relationship between handle travel and the size of the leak.

1. Set handle.
Turn the locked knobs counterclockwise until the valve handle is approximately parallel to the side of the valve body.
2. Close valve using roughing screw as follows.
 - a) Carefully remove the hole cover from the top of the valve.



CAUTION

Do not exceed 8 ft.-lbs. of torque or the sapphire may be fractured.

- b) With a 5/16" Allen wrench, tighten the roughing screw to 6 ft.-lbs. of torque.
- c) Replace the hole cover.
- d) The valve should now be leak-tight, but this can be determined reliably only with a leak detector. If the valve leaks across the seal, refer to the following paragraph.
3. Adjust knobs as follows.
 - a) Turn the knobs together counterclockwise until a leak is generated.
 - b) Turn the knobs clockwise until the valve is closed leak-tight.
 - c) Turn the knobs two additional turns clockwise to provide the proper amount of over-drive.
 - d) Loosen the knobs without allowing the fine-drive screw to turn then turn the inner knob clockwise until the collar is against the handle. Lock the outer knob against the inner one.
 - e) Two counterclockwise turns of both knobs together should open a leak.

IF VALVE WILL NOT CLOSE LEAK-TIGHT

If the valve is not leak-tight across the sapphire-gasket seal after the knobs have been turned to the stop position, one of several problems may be the cause.

1. The gasket has been compressed and the stops must be reset.
2. The valve, sapphire, and/or gasket are contaminated and need cleaning.
3. The gasket is scratched, nicked, or compressed beyond further use and must be replaced.
4. The sapphire is fractured and must be replaced.

The following procedures should be followed in the order listed.

- a) Follow the steps outlined in para. "To establish a new stop position".
If the valve is still not leak tight, proceed to step "b" below.
- b) Disassemble, clean, and inspect the sealing components.
Particles, oxide on the gasket, or other contaminants may prevent the valve from closing leak-tight. Disconnect the valve from other components and disassemble. Inspect and clean the valve, sapphire, and gasket as described in the following steps.

Disassemble

Refer to the figure "Variable leak valve assembly drawing".

- a) Turn both knobs counterclockwise four turns.
- b) Carefully remove the pressed-in hole cover (11) and with a 5/16" Allen wrench loosen the roughing screw two turns.
- c) Use a clean 1/4" Allen wrench to remove the gasket assembly (1). The thread is normal right hand and 20-25 ft.-lbs. of torque will be required to loosen it.
- d) Clean the sapphire removal tool with acetone, insert it into the hole that held the gasket assembly, and engage the fingers of the tool with the slots on the periphery of the sapphire assembly.

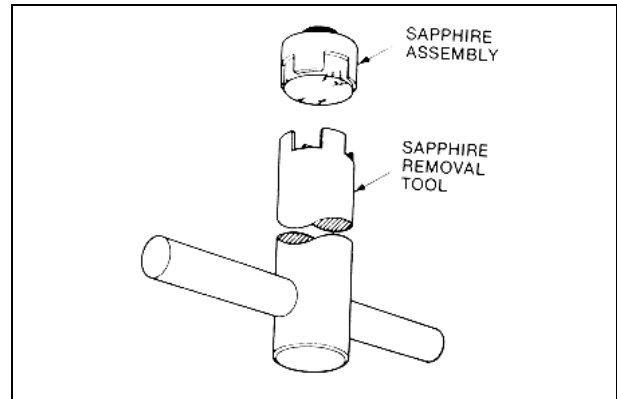

Sapphire removal

- e) Turn the valve and tool upside down and turn the tool counterclockwise to remove the sapphire assembly. Four full turns will disengage the threads.
- f) Maintain the upside down position of valve and tool, and lower the tool and sapphire assembly from the valve.

Inspect and clean sapphire

- a) Check the sapphire to be sure that it has no cracks or chips. Any fractures will require replacement of the sapphire assembly.
- b) Check the cleanliness of the polished face by viewing light reflected from its surface. Flush the face with acetone (CP grade recommended) and wipe off any film or grease. Be sure that no particles remain on the sapphire when ready for re-assembly.

Inspect and clean valve body

- a) Check the valve body for any loose particles of other contaminants.
- b) Remove any contaminants by flushing acetone through the inlet gas fitting while holding the valve upright.
- c) Blow out the valve with a clean, dry gas through the inlet gas fitting.

CAUTION

Do not use compressed air to blow out the valve. The possible high content of particles, water vapour, and oil will contaminate the valve. Re-cleaning and possible gasket replacement may then be required.

Inspect and clean gasket assembly

- a) Inspect the copper alloy gasket to be sure that it is clean, smooth, free of oxide, and protrudes above the surface of the gasket collar by at least 0.002 inch. A hand lens or microscope will facilitate inspection of the surface.
- b) If the top surface of the gasket is scored, scratched, or nicked, the gasket assembly must be replaced.
- c) If the copper portion of the assembly does not protrude at least 0.002 inch above the collar, the gasket assembly must be replaced.
- d) Oily films or other residue should be removed using acetone.
- e) Oxide or other slight surface imperfections can generally be removed by polishing with a very fine rouge paper. When polishing, rotate the gasket assembly about its centre axis to avoid leaving scratches that cross the sealing surface. Clean the gasket with acetone after polishing.
- f) Keep the gasket free of contamination while awaiting re-assembly.

Re-install sapphire assembly

- a) Hold the sapphire removal tool upright and attach the sapphire assembly to the tool engaging the four slots. Be certain that the tool is clean.
- b) With the valve in the upside down position, carefully insert the tool and sapphire into the valve. Turn the tool clockwise to engage the threads. *Only light finger pressure is required* to tighten the assembly into the valve properly.



CAUTION

Do not overtighten the sapphire assembly with the removal tool.

Heavy tightening can cause the tool to raise a burr in the slots of the sapphire assembly. These burrs can prevent subsequent removal of the sapphire assembly from the valve.

Re-install gasket assembly

- a) To avoid contamination, hold the valve in the upright position. Install the gasket assembly and tighten finger-tight.
- b) Tighten the gasket assembly to 22 to 24 ft.-lbs. of torque. Check that the Allen wrench is clean before use.

NOTE

Install the valve on the vacuum system as soon as possible after re-assembly to avoid particle contamination. If storage is necessary, place valve in a clean polyethylene bag and close the bag securely. Avoid setting the valve on dusty surfaces.

Leak-check and adjust closure

Reset the handle position, roughing screw and knobs, and leak-check the valve as described in para. "Adjustment of handle position".

LUBRICATION INSTRUCTIONS

Fel-Pro C-100 is recommended for lubrication. After each bakeout cycle, lubricate the threads of the fine-drive screw. After every three bakeouts at temperatures over 300°C, disassemble the drive mechanism and lubricate it. Use the SST brush to remove flaky or caked-on lubricant before re-lubrication.

Refer to the figure "Variable leak valve assembly drawing".

1. Open the valve by turning both knobs four counterclockwise turns.
2. Withdraw the two Phillips head screws on the upper part of the valve body and remove the cover.
3. Remove the roughing screw (10). Lubricate its threads and the spherical socket.
4. Insert the two Phillips head screws that held the cover into the two pivot rods and, using the screws as handles, pull out the rods.
5. Lift out the handle. Its sides have been sprayed with a semipermanent coat of molybdenum-disulphide. The lubricant in most cases will not require replenishing. If the user judges that re-lubrication is necessary, a small amount of Fel-Pro C-100 should be applied to each side of the handle where it guides in the body.
6. Remove the rod assembly and lubricate both ends. Replace it.
7. Lubricate the pivot rod holes in the handle. Do not lubricate the pivot rod holes in the body.
8. Reassemble the handle and pivot rods.

9. Replace the roughing screw, valve cover, and two small screws.
10. Follow the procedure specified in para. "Adjustment of handle position" to close the valve and adjust the drive mechanism for proper operation.

LOSS OF SENSITIVITY AT HIGH LEAK RATES

Repeated bakeouts at 450°C will result in partial annealing and a loss of tension in the spring washers that provide the force to open the valve. This will be evidenced by decreasing sensitivity of control at high leak rates. This is not a common situation, but may occur after months of use under high-temperature conditions. Replacement of the spring washers and adjustment are required.

1. Disassemble drive mechanism.
 - a) Open the valve four counterclockwise turns of the knobs.
 - b) Withdraw the two Phillips head screws on the upper part of the valve body and remove the cover.
 - c) Remove the roughing screw.
 - d) Remove the two pivot rods by grasping each with a screw. Lift out the handle.
2. Replace spring washers.
 - a) With a 3/4" hex-socket wrench, remove the nut above the spring washers.
 - b) Remove and replace the spring washers.
 - c) Replace the 3/4" hex nut.

3. Adjust tension.
 - a) With a 1/4" hex-socket-wrench, tighten the nut above the spring washers just enough so that there is no clearance between the washers and the nut.
4. Reassemble.
 - a) Replace the handle, pivot rods, roughing screw, and cover.
 - b) Repeat the closure adjustment to reposition the handle and knobs.

DISPOSAL

Meaning of the "WEEE" logo found in labels

The following symbol is applied in accordance with the EC WEEE (Waste Electrical and Electronic Equipment) Directive.

This symbol (**valid only in countries of the European Community**) indicates that the product it applies to must NOT be disposed of together with ordinary domestic or industrial waste but must be sent to a differentiated waste collection system. The end user is therefore invited to contact the supplier of the device, whether the Parent Company or a retailer, to initiate the collection and disposal process after checking the contractual terms and conditions of sale.

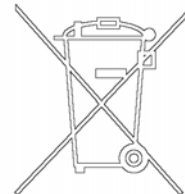

REPLACEMENT PARTS

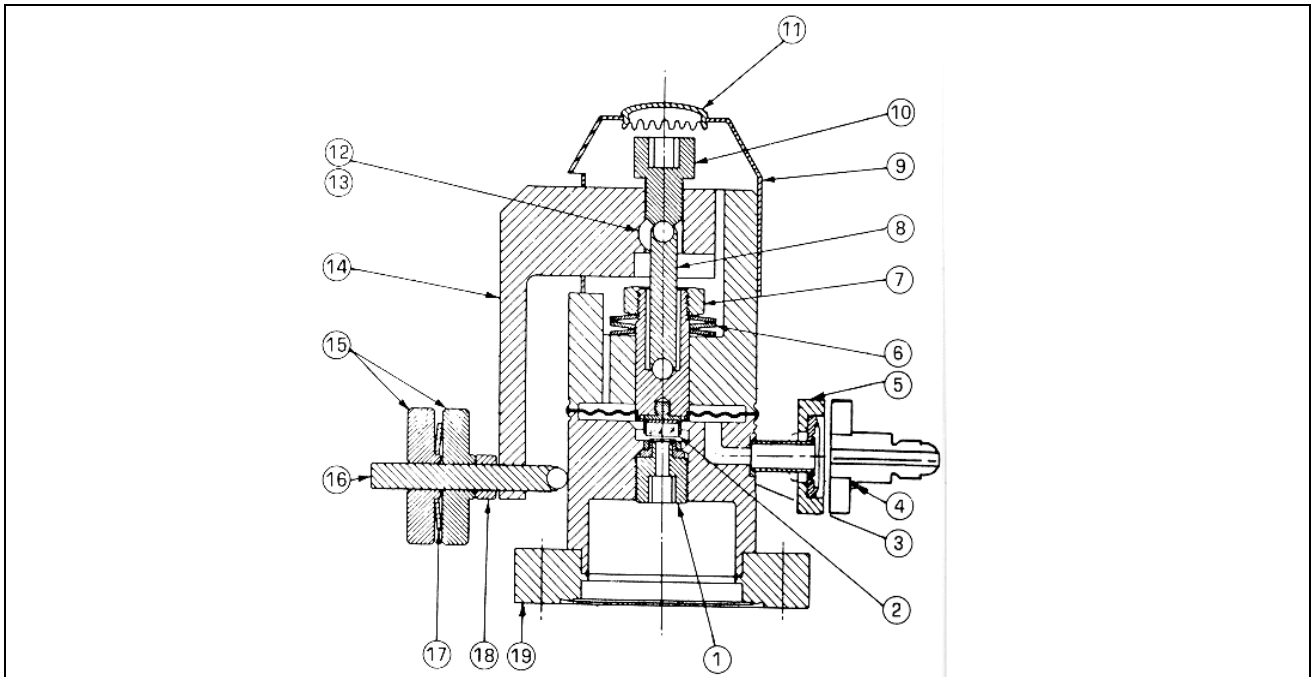

Variable leak valve assembly drawing

Please refer to the preceding figure

Ref. item	Description	Q.ty req.d	Part Number
1*	Gasket assembly	1	953-5050
2*	Sapphire assembly	1	953-0072
6*	Spring washer	3	
7	Nut	1	
8	Rod assembly	1	
9	Cover	1	
10	Roughing screw	1	
11	Hole cover	1	
12	Pivot rod	2	
13	Pan head screw, 8-32 x 1/4 lg	2	
14*	Handle	1	
15*	Knob	2	
16*	Fine drive screw assembly	1	
17*	Fine drive spring washer	1	
18*	Collar	1	
---	Sapphire removal tool	1	SR0061417400
---	5/16" Allen wrench	1	
---	1/4" Allen wrench	1	
---	SST brush	1	
---	High temperature lubricant Fel-Pro C-100	1	
	Repair Kit		962-0014

* This item is part of Repair Kit 962-0014.

ACCESSORIES

Description	Part number														
Mating ConFlat flange 2 3/4" -rotatable	F0275-0150-RCE														
Mating ConFlat flange 2 3/4" -non-rotatable	F0275-0150-NCE														
Copper gasket for 2 3/4" CFF – Pkg./10	FG-0275-CI														
Screw and nuts for 2 3/4" CFF – Pkg./25	FB-0275-CI														
Mating Mini-ConFlat flange 1 1/3" - rotatable	F0133-0075-RCEW														
Mating Mini-ConFlat flange 1 1/3" – non-rotatable	F0133-0075-NCE														
Copper gasket for 1 1/3" – pkg./10	FG-0133-CI														
Screw and nuts for 1 1/3" – pkg./25	FB-0133-C														
Flare fitting adapter kit Consists of: <table data-bbox="236 600 742 817" style="display: inline-table; vertical-align: top;"> <thead> <tr> <th></th> <th style="text-align: right;">Q.ty</th> </tr> </thead> <tbody> <tr> <td>• Adapter flare – Mini-ConFlat</td> <td style="text-align: right;">1</td> </tr> <tr> <td>• Mini flange screws 8-32"</td> <td style="text-align: right;">6</td> </tr> <tr> <td>• Nut for mini flange 8-32"</td> <td style="text-align: right;">6</td> </tr> <tr> <td>• Gasket for mini flange</td> <td style="text-align: right;">10</td> </tr> <tr> <td>• Fitting nut (28629886-00)</td> <td style="text-align: right;">1</td> </tr> <tr> <td>• Fitting sleeve (28629887-00)</td> <td style="text-align: right;">1</td> </tr> </tbody> </table>		Q.ty	• Adapter flare – Mini-ConFlat	1	• Mini flange screws 8-32"	6	• Nut for mini flange 8-32"	6	• Gasket for mini flange	10	• Fitting nut (28629886-00)	1	• Fitting sleeve (28629887-00)	1	951-5117
	Q.ty														
• Adapter flare – Mini-ConFlat	1														
• Mini flange screws 8-32"	6														
• Nut for mini flange 8-32"	6														
• Gasket for mini flange	10														
• Fitting nut (28629886-00)	1														
• Fitting sleeve (28629887-00)	1														